

# Dual Energy X-ray Inspection System

## ZKX100100



### Highlights

- Adjustable belt speed
- Large baggage and parcel screening
- Folding design for easy loading

### Standard

- Fingerprint console board
- Dual monitor operation desk
- Bi-directional scanning

### Optional

- Video surveillance
- Face recognition
- Energy saving function
- Rat expelling function

### Introduction

ZKX100100 X-ray inspection system increases the operator's ability to identify potential threats; the device is designed to scan the objects up to a size of 100 × 100cm.

ZKX100100 uses reliable high quality dual energy X-ray generator. With the superb image algorithm, ZKX100100 could offer clear scanning image, which allows operators to identify potential threat items visually. Also, ZKX100100 equipped with a lowered conveyor height to make it easier to put the luggage on.

ZKX100100 has innovative biometric identify function for operators, improving the security of system and preventing operator from forgetting password.

With ergonomic modern design, ZKX100100 could help operators to identify suspicious items fast and accurately.

## Specifications

<b>Tunnel Size</b>	W1008mm × H1009mm
<b>Speed</b>	0.20 m/s
<b>Height of Transmission Belt</b>	387 mm
<b>Maximum Load</b>	200 kg (Adequate distribution)
<b>Wire Resolution</b>	38 AWG
<b>Space Definition</b>	Horizontal $\Phi$ 1.0mm \ Vertical $\Phi$ 2.0mm
<b>Penetrate Definition</b>	32 AWG
<b>Penetration</b>	30 mm steel board
<b>Monitor</b>	21.5 inch LED X 2
<b>System Function</b>	High density alert, Explosive/ Drug auxiliary detect, TIP, Luggage counter, date/time display, User management, Training.
<b>Film Safety</b>	ASA/ISO1600 standard of film safety

## X-ray System

<b>Tube Voltage</b>	160 KV
<b>Cooling</b>	Seal oil cooling / 100%
<b>Radiation Leak Dosage</b>	0.2 $\mu$ Gy/h (5cm from the surface)

## Installation Specification

<b>Package Size</b>	L2600mm × W1520mm × H1920mm
<b>Package Size of Console Desk</b>	L1320mm × W850mm × H1320mm
<b>Package Weight</b>	1250KG+135KG (Console desk)
<b>Power Consumption</b>	1 kVA
<b>Noise</b>	55.8 dB(A)

## Dimension

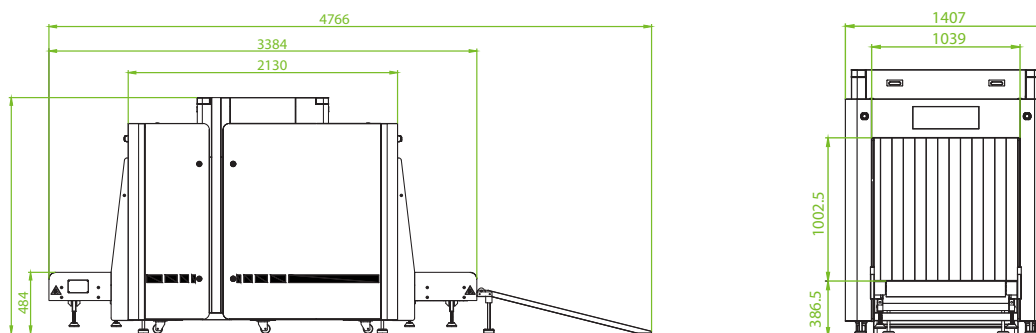

### MySolutions Inc.

Authorized Distributor of ZKTeco Products in the Philippines  
 2F 201 Del Monte Ave. Brgy. Masambong QC  
 Tel: (02) 8-365-8488 | (02) 8-367-8188  
 (02) 8-257-7696 to 99  
 Email: sales@mysolutions.ph

© Copyright 2017. ZKTECO CO.,LTD. ZKTeco Logo is a registered trademark of ZKTeco or a related company. All other product and company names mentioned are used for identification purposes only and may be the trademarks of their respective owners. All specifications are subject to change without notice. All rights reserved.

