

NASOKI

BATTERIES

TALL TUBULAR CONVENTIONAL BATTERY (100Ah to 200Ah)



 www.nasokibattery.com

 sales@eastmanglobal.com

TECHNICAL SPECIFICATION - Tall Tubular Conventional Battery

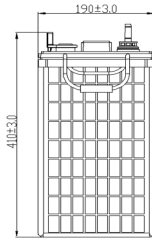
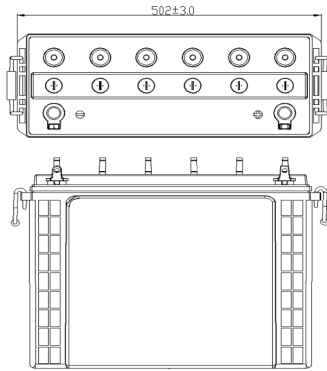

Product Features :-

1. Robust Tubular with High Pressure diecasted spine- resulting low rate of spine corrosion.
2. Spill Proof Vent plug – resulting in no spillage on top and low controlled acid fumes.
3. Optimized Negative paste receipt for fast charge acceptance
4. Consistent backup throughout life
5. Excellent behavior in PSOC condition as compare
6. Low Self Discharge
7. Excellent performance on deep cyclic application as compare to AGM VRLA
8. Very High Design & Service Life
9. Low water loss

Technical Specifications

Model	Nominal Voltage	Rated Capacity 20 Hr @ 27°C (Ah)	Dimensions in mm			Filled Battery Weight [Kg] [±3%]	Terminal Type
			Length [± 3 mm]	Width [± 3 mm]	Height [± 3 mm]		
NS100 [12 V 100 AH @ C20]	12	100	505	190	410	48	L
NS150 [12 V 150 AH @ C20]	12	150	505	190	410	53.95	L
NS200 [12 V 200 AH @ C20]	12	200	505	190	410	61.11	L

Electrical Parameters & Charging Profile

Battery Specified Capacity Test @ 27 °C						
	C20 @10.5V	C10 @10.5V	C7 @10.5V	C5 @10.5V	C3 @10.5V	C1 @10.5V
NS100 [12 V 100 AH @ C20]	100	90	83	75	65	45
NS150 [12 V 150 AH @ C20]	150	135	124	112	97	68
NS200 [12 V 200 AH @ C20]	200	180	166	150	129	90
Ah & Wh Efficiency						
Ah Efficiency	>90%		Wh Efficiency		>75%	

- Poly Components Material :- Polypropylene Co polymer
- Watering system :- Individual to every cell in Monobloc
- Testing Parameters :- IS 13369:1992 & IEC 60896-11

Charging Profile

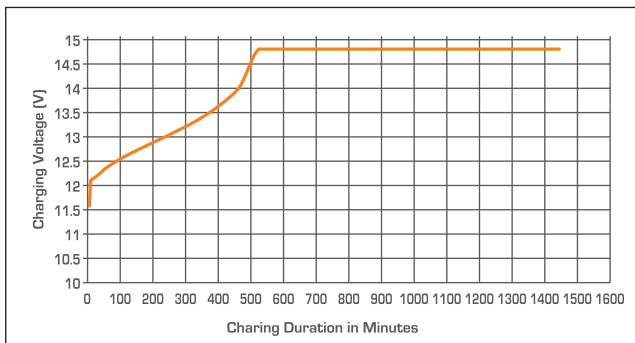

Self Discharge Characteristics @ Different Temperature

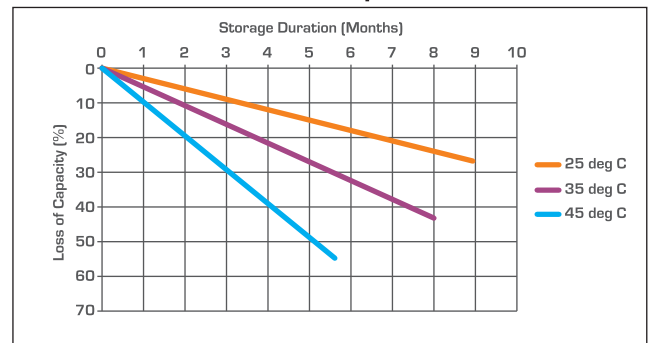

State of Charge Measure of Open-circuit Voltage @ 27°C

State of Charge	Specific Gravity	Voltage
100%	1.245-1.275	12.55V-12.70V
75%	≤ 1.225	≤ 12.4V
50%	≤ 1.190	≤ 12.1V
25%	≤ 1.155	≤ 12.0V
0%	1.120	11.8V

Discharging Characteristics at various rates @ 27°C

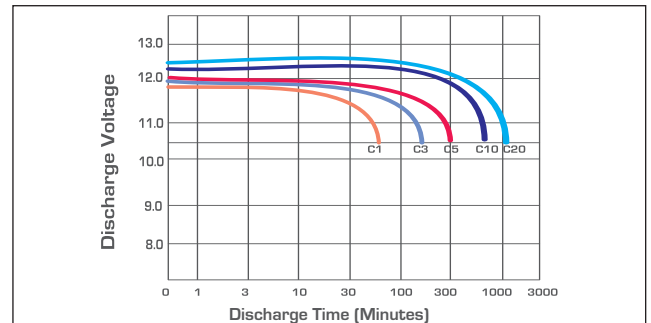

Service (Float) Life and Temperature

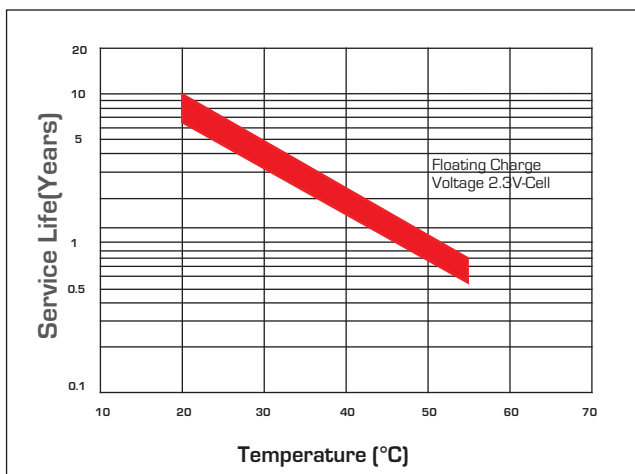

Expected Capacity vs Temperature

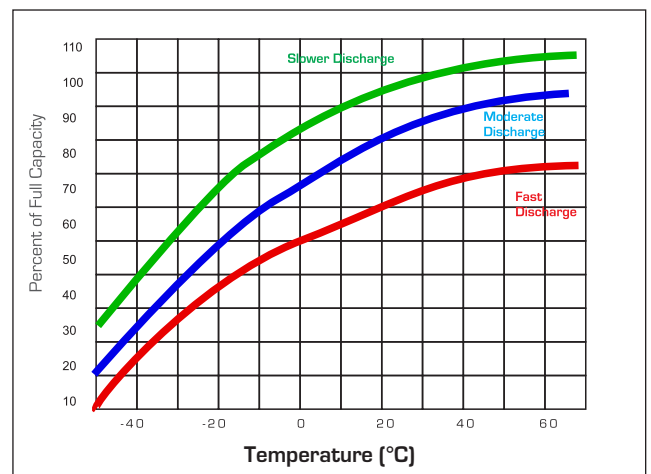

Eastman Battery Manufacturing Certified by Vincotte for



Specific Gravity & Self Discharge w.r.t. Temperature

	Add	Subtract
CHARGING TEMPERATURE COMPENSATION	0.005 volt per cell for every 1°C below 25°C	0.005 volt per cell for every 1°C above 25°C or
	0.0028 volt per cell for every 1°F below 77°F	0.0028 volt per cell for every 1°F above 77°F
OPERATIONAL DATA	Operating Temperature	Self Discharge
	-4°F to 131°F [-20°C to +55°C] At temperatures below 32°F (0°C) maintain a state of charge greater than 60%.	As per discharge Graph

Expected Life

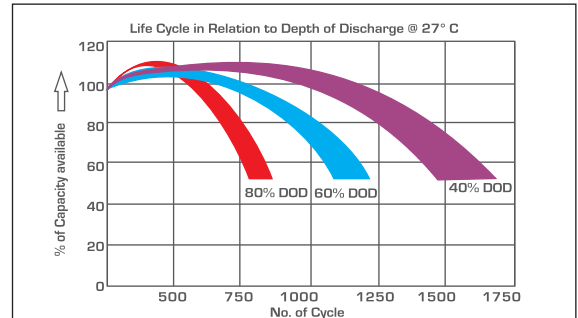

Charging Instructions

Charger Voltage Settings [at 77° F/ 25°C]			
System Voltage	12V	24V	48V
Maximum Charge Current	0.2C10		
Maximum Absorption Phase Time (hours)	4		
Absorption Voltage	14.4	28.8	57.6
Float Voltage	13.6	27.2	54.4
Equalization Voltage	16	32	64
Do not install or charge batteries in a sealer or non-ventilated compartment. Constant under or overcharging will damage the battery and shorten its life as with any battery.			
Periodic Charge	Provide a periodic freshening charge to maintain a SOC greater than the threshold of 70%		

Comparison in between Nasoki TTC & AGM VRLA

S.No	Parameter	Nasoki Tall Tubular Conventional	AGM VRLA
1	Plate Technology	Tall Tubular Plate	Flat Pasted Plate
2	Life w.r.t Application	Excellent performance on cyclic application	Not good for deep cycle application.
3	Application	"Power Backup Solution - Solar/Inverter/UPS Suitable for Float Application above 1 Hour discharge rate"	"Power Back up - Inverter/UPS Good for float & stand by application"
4	Electrolyte	Free Flow Electrolyte	Electrolyte in-between AGM
5	Water Loss	Low	Negligible
6	Water Top up	Low water top up	No water top up throughout Warranty Life
7	Life Extension	Long life with regular water top up	
8	Self Discharge	Low <3.0%	Very Low < 2.0%
9	Life Cycle w.r.t DOD @27° C @ 80% DoD	900 Cycle	450 Cycle
10	Spillage	Low Spill-proof	Spill-proof
11	Fumes	Low Fumes	No
12	Recovery in PSOC	Excellent	Low
13	Charger Settings	Generic set point for chargers	Required special set point for chargers
14	Operating Temperature Range	-20 Degrees to +55 Degrees	-15 Degrees to +40 Degrees
15	Terminal Type	L-Type Terminal	Stud Type Terminal

Terminal Configuration :-
Terminal Type :- L
Terminal Height :- 24 mm
Torque Value :- 8-10 N.m
Bolt Type :- M8

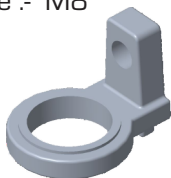

Vent Plug Type :-
M22 coin type



Vent Plug Type :-
M30 Dummy Plug



EASTMAN AUTO & POWER LTD.